



**SPARCO HARNESS BAR  
1995-2004 FORD MUSTANG  
PART # 30012**

**DISCLAIMER**

Motorsports are dangerous. No warranty or representation is made as to product's ability to protect the user from any injury or death; the user assumes that risk. Sparco Motor Sports' products are legal in all 50 states for use on racing vehicles which may never be used on a highway. Not applicable or intended for street or highway use.

**INSTALLATION**

**NOTE: You will need a #50 Torx bit for this installation**

1. Assemble the harness support rods as shown below using the provided heim joints and nuts. Leave at least  $\frac{1}{4}$ " of thread showing on each heim joint to allow for adjustment during installation. Do not fully tighten the nuts at this time. **NOTE: One end of each of the support rods has reversed thread.**



2. On both sides of the vehicle's interior, unsnap the plastic factory shoulder belt bolt cover and remove the Torx head bolt as shown here.



3. Remove the factory retaining washer and remove the factory bolt from the factory harness. Assemble the hardware as shown and install the harness bar into the vehicle. Due to slight tolerance differences from vehicle to vehicle, you may need to bend the ends slightly for proper fit. **Refer to step number 6 for proper factory harness routing.** Do not tighten the bolts at this time.

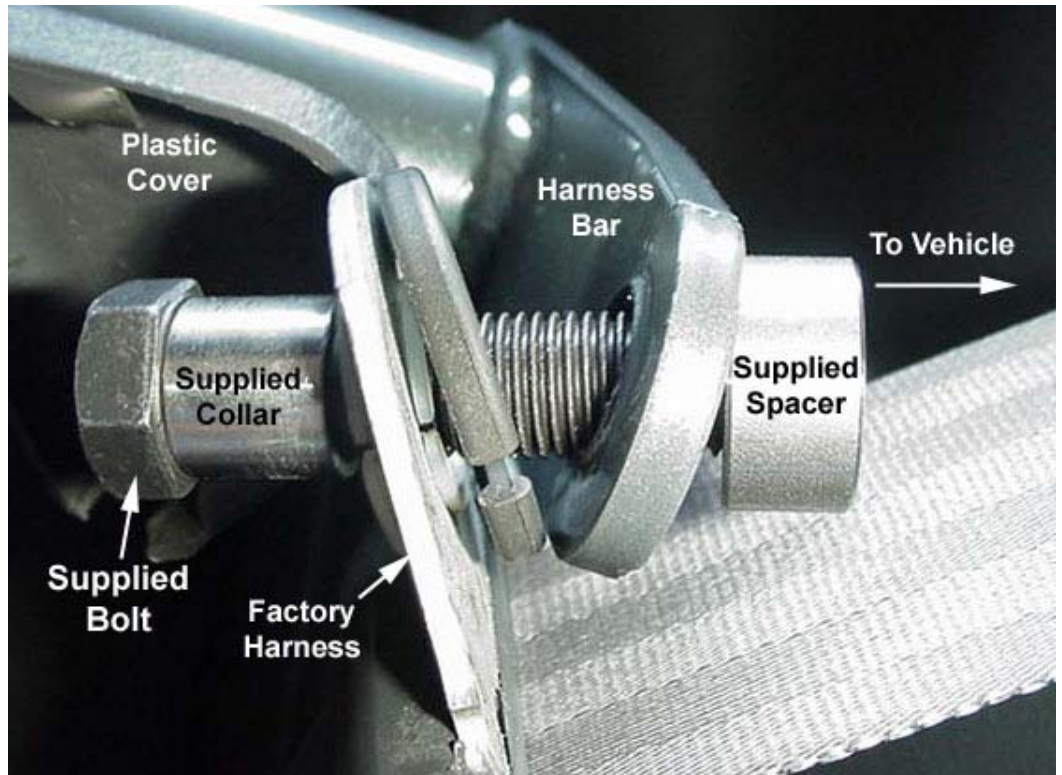

4. On both sides of the vehicle's interior, loosen and remove the lower seat belt Torx bolt from the vehicle.



5. Using the supplied bracket, support rod and hardware, assemble the bracket as shown. Reinstall the factory Torx head bolt into the factory mounting position.  
**NOTE: Tighten the support rod nut and support rod mounting hardware before reinstallation.**

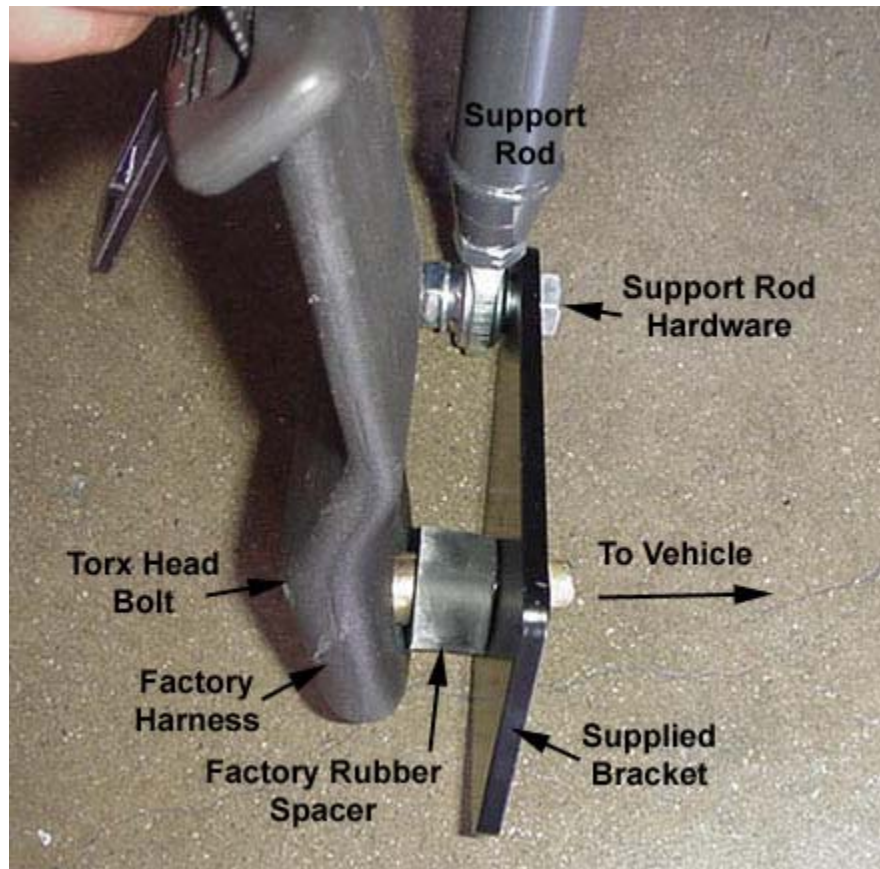

The finished lower bracket installation should look like this:



6. Connect the support rods to the harness bar using the supplied bolts, washers, and nuts. Do not fully tighten at this time. Check for proper installation and adjust as necessary. Tighten all bolts and nuts. The finished installation should look like this:

